



ZHEJIANG HANGCHA IMP. & EXP. CO., LTD.

Factory site: 666 Xiangfu Road,
Hangzhou, Zhejiang, China (311305)

Tel: +86-571-88926735 88926755
Fax: +86-571-88926789 88132890

sales@hcforklift.com
www.hcforklift.com



Follow us on
Facebook



Follow us on
YouTube



Follow us on
WeChat



Download "Hangcha
Forklift" App



ISO14001
ISO14001:2015



ISO9001
ISO9001:2015



HANGCHA trucks conform
to the European Safety
Requirements.

2023 VERSION 3 / COPYRIGHT 2023/05

HANGCHA GROUP CO., LTD. reserves the right to make any changes without notice concerning colors, equipment, or specifications detailed in this brochure, or to discontinue individual models. The colors of trucks, delivered may differ slightly from those in brochures.



XH SERIES HIGH-VOLTAGE LITHIUM BATTERY FORKLIFT

with capacity of 6,000 to 10,000kg



The World of Hangcha



XH SERIES HIGH-VOLTAGE LITHIUM BATTERY FORKLIFT

Independently developed by Hangcha on the basis of decades of deep understanding of electric forklifts and internal combustion forklifts, the dedicated XH series heavy-duty high-voltage lithium battery forklifts are a new series of products with a new energy vehicle voltage platform and a pioneered special structure that represents a breakthrough over the traditional design concept. Breaking through the perception of drive electric forklift, the series of products supersede the internal combustion forklifts and redefine the new generation of electric forklifts in terms of efficiency, power, reliability, etc..

THE *Plus*
FOR YOUR
BUSINESS

VOLTAGE

309 V

SPEED MODELS

3

MAX. GRADEABILITY

30%

TRAVEL SPEED

32km/h

WATER RESISTANCE

IPX4

PROTECTION RATE

IP67

Stylish exterior

/ With the inherited classic exterior design of the dedicated XC lithium battery forklift and a smooth and sturdy profile, the whole vehicle is impact, elegant, stylish and sturdy.



COMMITTED TO IMPROVING

FASTER & MORE EFFICIENCY.

Compared with low-voltage lithium battery forklifts, high-voltage lithium battery technology can save about 40% of the overall cost during the service cycle.

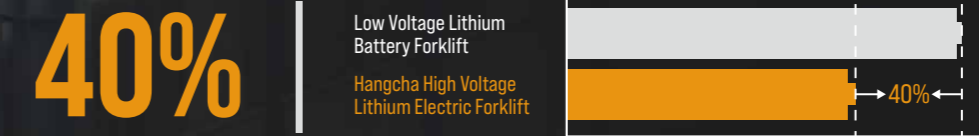

Compared with fuel forklifts, high-voltage lithium battery technology can save about 90% of the overall cost during the service cycle.

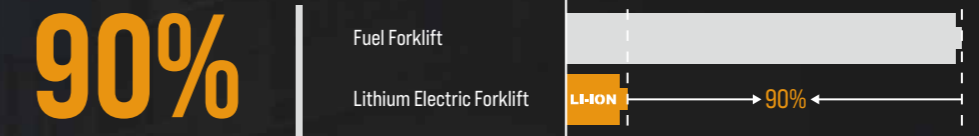

4000 CYCLES OF CHARGING **75% LI-ION**

Under normal charging and discharging conditions, the lithium battery of Hangcha products has a capacity retention rate of more than 75% and a life span of up to 10 years after 4000 cycles of charging and discharging.

Through disruptive battery and fast charging technology, the charging time is greatly shortened.

Get the battery fully charge:



Hangcha High Voltage Electric Forklift (6.0-7.0t)

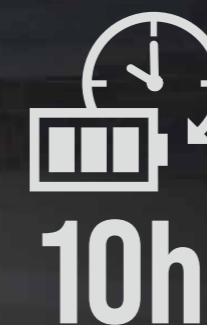

Electric Forklift

POWER PERFORMANCE COMPARISON

	High Voltage Lithium Electric Forklift	Fuel Forklift
Travel speed, laden/unladen	29/32km/h	15-20km/h
Lift speed, laden/unladen	400/470mm/s	430/470mm/s
Max. gradeability, S2-5min, laden/unladen	24/30%	15%-20%

Fast charging makes it possible for the whole vehicle to work continuously, shortening the waiting time and greatly improving efficiency.

HIGH-VOLTAGE

93.3Kwh

Battery capacity



EFFICIENT AND DURABLE



Standard large-capacity lithium battery



Charging port

Ultra-long battery life

- / Standard large-capacity lithium battery meets long battery life requirements.
- / Both the drive and operating systems are vehicle-grade permanent magnet synchronization systems, being energy-saving and efficient;
- / With 309V high-voltage platform, the vehicle boasts of a smaller current and very low heat loss;
- / The vehicle uses an overall controller to control the traction motor controller assembly and the driving motor controller assembly to form a highly independent, light-weighted, efficient and intelligent drive system.

Quick charge

- / The standard battery with superfast charging technology needs only 1.0h(6.0-7.0t)/1.5h(8.0-10t) to charge fully;
- / Optional slow-charge charger (2h(6.0-7.0t)/3h(8.0-10t) to charge fully), cost-effective and economical.

Internal combustion condition

- / Both the drive and operating systems are vehicle-grade permanent magnet synchronization systems. Equipped with a high speed ratio gearbox, the driving speed, upslope degree and acceleration performance surpass that of internal combustion vehicles.
- / It adopts the same structural design of drive axle, steering axle and tires as internal combustion forklifts, which can meet the demand of high-intensity operating conditions.
- / With regard to the series of products, a water cooling system with a good heat dissipation effect is used on a new energy forklift for the first time, so that the forklift can carry out long-time and high-intensity operations as internal combustion forklifts.
- / It meets all-weather operating conditions and is usable under severe operating conditions such as cold storage, heavy rain and waterlogged roads.

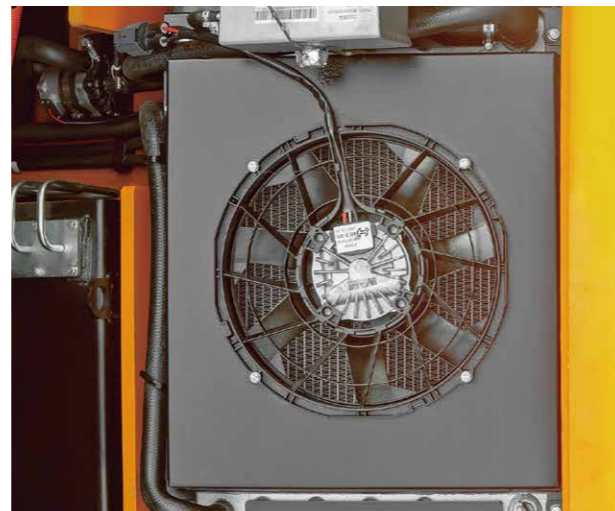

Cooling system

SAFE AND RELIABLE

The cover of the vehicle is designed to be sealed to the water resistance level of IPX4 for the body. All the motor, electronic controls and high-voltage components reach the dust and water resistance level of IP67, a high protection level adequate to withstand harsh operating environments and ensure safety and reliability.



The electrical system is equipped with high-voltage interlocks, insulation detection and vehicle-grade safety means. The MSD maintenance switch enables one-click power-down and safer maintenance.



The standard configuration provides a fork descending buffering function. In addition, an optional electronic control function for buffering the fork's ascending is provided to protect the goods from falling and damaging the ground.



An optional OPS seat sensing feature is provided to enable high safety by disabling the descending, lifting and driving when the driver leaves the seat and giving out an alarm when the driver leaves the seat without activating the hand brake.

XH Series 6.0-10t High-voltage Lithium Battery Forklift Specification

Distinguishing mark	HANGCHA GROUP CO.,LTD.								
	1.1	Manufacturer		CPD60-XHY2G	CPD70-XHY2G	CPD80-XHY2G	CPD80-XHLY2G	CPD90-XHY2G	CPD100-XHY2G
1.2	Manufacturer's type designation		CPD60-XHY2G	CPD70-XHY2G	CPD80-XHY2G	CPD80-XHLY2G	CPD90-XHY2G	CPD100-XHY2G	
1.3	Drive: electric (battery or mains), diesel, petrol, fuel gas		Electric	Electric	Electric	Electric	Electric	Electric	
1.4	Operator type: hand, pedestrian, standing, seated, order-picker		Seated	Seated	Seated	Seated	Seated	Seated	
1.5	Rated capacity/rated load	Q (kg)	6000	7000	8000	8000	9000	10000	
1.6	Load centre distance	c (mm)	600	600	600	900	600	600	
1.7	Load distance, centre of drive axle to fork	x (mm)	603.5	608.5	714	726	726	726	
1.8	Wheelbase	y (mm)	2300	2300	2500	2500	2500	2500	
Weight	2.1	Service Weight	kg	9200	9700	11800	14200	13400	14200
	2.2	Axle loading, laden front/rear	kg	13400/1800	14970/1730	17700/2100	19560/2640	20080/2320	21640/2560
	2.3	Axle loading, unladen front/rear	kg	4250/4950	4310/5390	5500/6300	6370/7830	6250/7150	6350/7850
Tyres, chassis	3.1	Tyres: solid rubber, superelastic, pneumatic, polyurethane		Pneumatic	Pneumatic	Pneumatic	Pneumatic	Pneumatic	Pneumatic
	3.2	Tyre size, front		8.25-15-14PR	8.25-15-14PR	9.00-20-14PR	9.00-20-14PR	9.00-20-14PR	9.00-20-14PR
	3.3	Tyre size, rear		8.25-15-14PR	8.25-15-14PR	9.00-20-14PR	9.00-20-14PR	9.00-20-14PR	9.00-20-14PR
	3.4	Wheels, number front / rear (x = driven wheels)		4x/2	4x/2	4x/2	4x/2	4x/2	4x/2
	3.5	Tread, front	b10 (mm)	1489	1489	1628	1628	1628	1628
	3.6	Tread, rear	b11 (mm)	1700	1700	1700	1700	1700	1700
Dimensions	4.1	Tilt of mast/fork carriage forward/backward	$\alpha/\beta(^{\circ})$	6/12	6/12	6/12	6/12	6/12	6/12
	4.2	Height, mast lowered	h1 (mm)	2500	2500	2700	2850	2850	2850
	4.3	Free lift	h2 (mm)	160	160	200	200	200	200
	4.4	Lift	h3 (mm)	3000	3000	3000	3000	3000	3000
	4.5	Height, mast extended	h4 (mm)	4407	4407	4210	4555	4555	4555
	4.6	Height of overhead guard (cabin)	h6 (mm)	2440	2440	2560	2560	2560	2560
	4.7	Seat height/stand height	h7 (mm)	1276	1276	1387	1387	1387	1387
	4.8	Overall length	l1 (mm)	4753.5	4758.5	5474	5806	5486	5486
	4.9	Length to face of forks	l2 (mm)	3553.5	3558.5	3974	3986	3986	3986
	4.10	Overall width	b1 (mm)	1990	1990	2197	2197	2197	2197
	4.11	Fork dimensions	s/e/l (mm)	60×150×1200	65×150×1200	75×160×1500	85×160×1820	80×160×1500	80×160×1500
	4.12	Distance between fork-arms	bs (mm)	300/1850	300/1850	440/2000	440/2000	440/2000	440/2000
	4.13	Ground clearance, laden, below mast	m1 (mm)	200	200	250	250	250	250
	4.14	Ground clearance, centre of wheelbase	m2 (mm)	238	238	320	320	320	320
	4.15	Aisle width for pallets 1000 x 1200 crossways	Ast (mm)	5133.5	5138.5	5534	5546	5546	5546
	4.16	Aisle width for pallets 800 x 1200 lengthways	Ast (mm)	5333.5	5338.5	5734	5746	5746	5746
	4.17	Turning radius	Ws (mm)	3330	3330	3620	3620	3620	3620
Performance data	5.1	Travel speed, laden/unladen	km/h	28/31	28/31	29/32	29/32	29/32	29/32
	5.2	Lift speed, laden/unladen	mm/s	550/590	510/540	460/500	420/470	400/470	380/470
	5.3	Lowering speed, laden	mm/s	480/420	480/420	455	455	455	455
	5.4	Max. gradeability, laden/unladen	%	34/30	30/30	26/30	22/30	24/30	22/30
	5.5	Service brake		Hydraulic	Hydraulic	Hydraulic	Hydraulic	Hydraulic	Hydraulic
	5.6	Parking brake		Mechanical	Mechanical	Mechanical	Mechanical	Mechanical	Mechanical
Electric-engine	6.1	Drive motor rating S2 60 min	kW	45	45	54.5	54.5	54.5	54.5
	6.2	Lift motor rating at S3 15%	kW	35x2	35x2	35x2	35x2	35x2	35x2
	6.3	Battery voltage, nominal capacity K5	V/Ah	309/228	309/228	309/302	309/302	309/302	309/302
	6.4	Battery weight	kg	740	740	890	890	890	890
7.1	Type of drive unit		AC	AC	AC	AC	AC	AC	
8.1	Manufacturer		Enpower	Enpower	Enpower	Enpower	Enpower	Enpower	
9.1	Operating pressure for attachments	MPa	19	19	20	20	20	20	

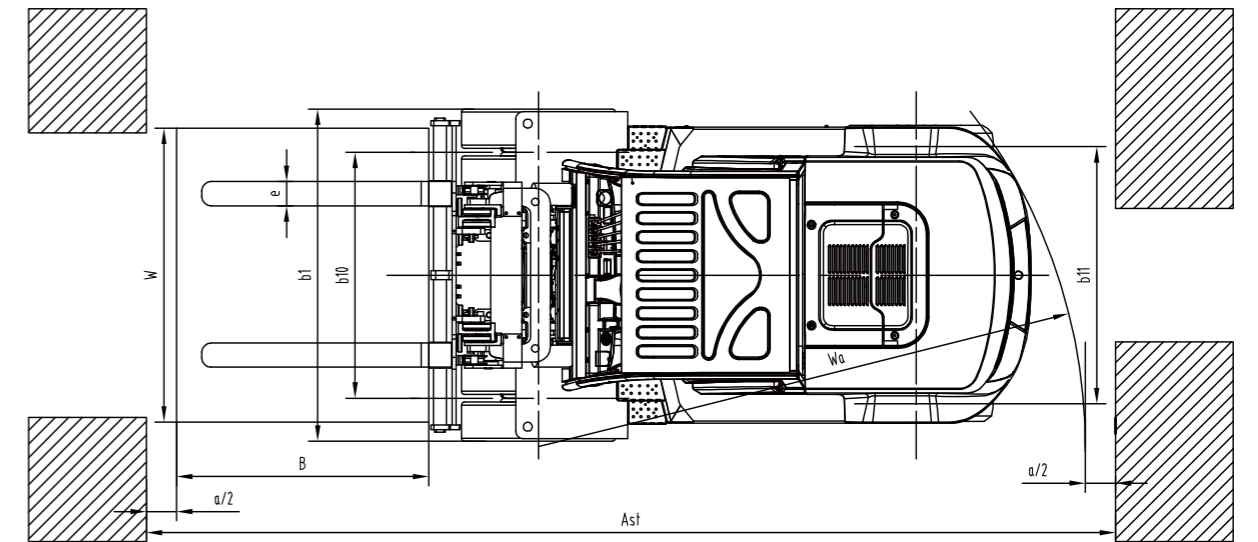
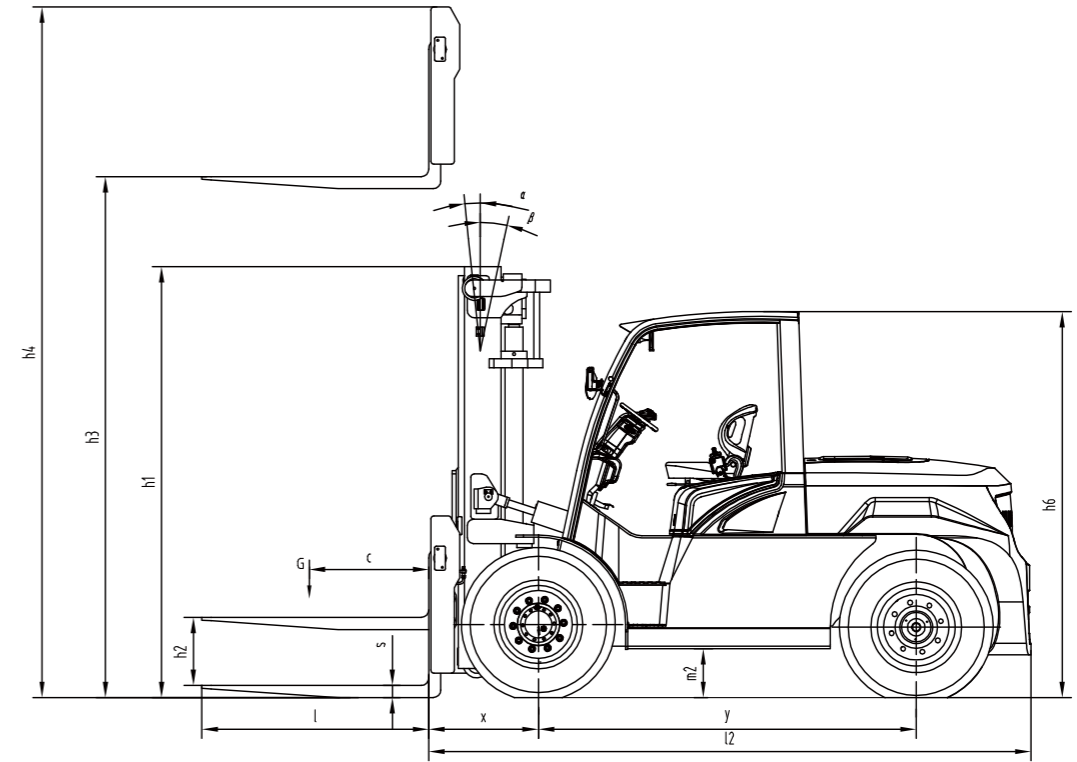

$Ast = a + Wa + x + B$ a: Clearance (200mm)

