



# XH SERIES HIGH-VOLTAGE LITHIUM BATTERY FORKLIFT

with capacity of 38,000 to 48,000kg



ZHEJIANG HANGCHA IMP. & EXP. CO., LTD.

Factory site: 666 Xiangfu Road,  
Hangzhou, Zhejiang, China (311305)

Tel: +86-571-88926735 88926755  
Fax: +86-571-88926789 88132890

sales@hcforklift.com  
www.hcforklift.com



Follow us on  
Facebook



Follow us on  
YouTube



Follow us on  
WeChat



Download "Hangcha  
Forklift" App



ISO14001  
ISO14001:2015



ISO9001  
ISO9001:2015



HANGCHA trucks conform  
to the European Safety  
Requirements.

2023 VERSION / © COPYRIGHT 2023/05

HANGCHA GROUP CO., LTD. reserves the right to make any changes without notice concerning colors, equipment, or specifications detailed in this brochure, or to discontinue individual models. The colors of trucks, delivered may differ slightly from those in brochures.

The World of Hangcha



# XH SERIES HIGH-VOLTAGE LITHIUM BATTERY FORKLIFT

Independently developed by Hangcha on the basis of decades of deep understanding of electric forklifts and internal combustion forklifts, XH series high-voltage counterweight lithium battery forklifts are a new series of high-voltage counterweight lithium battery forklifts that first use a new energy vehicle voltage platform and represent a breakthrough over the traditional design concept. Representing a redefinition of electric forklifts in terms of efficiency, power, reliability, etc., XH series forklift models have performance and operating condition completely superseding that of the internal combustion forklifts.

VOLTAGE

**618 V**

100% CHARGE FOR

**1 Hour**

WATER RESISTANCE

**IPX4**

SPEED MODELS

**3**

PROTECTION RATE

**IP67**

## Stylish appearance

/ With the inherited exterior design of X series internal combustion forklifts and a smooth and sturdy profile, the whole vehicle is stylish, sturdy and powerful, showing modern industrial aesthetics.

THE *Plus*  
FOR YOUR  
BUSINESS



# FASTER & MORE EFFICIENCY.

Compared with low-voltage lithium battery forklifts, high-voltage lithium battery technology can save about 40% of the overall cost during the service cycle.

## 40%

Low Voltage Lithium Battery Forklift  
Hangcha High Voltage Lithium Electric Forklift



Compared with fuel forklifts, high-voltage lithium battery technology can save about 90% of the overall cost during the service cycle.

## 90%

Fuel Forklift  
Lithium Electric Forklift



## 4000

CYCLES OF CHARGING



Under normal charging and discharging conditions, the lithium battery of Hangcha products has a capacity retention rate of more than 75% and a life span of up to 10 years after 4000 cycles of charging and discharging.

Through disruptive battery and fast charging technology, the charging time is greatly shortened.

Fast charging makes it possible for the whole vehicle to work continuously, shortening the waiting time and greatly improving efficiency.

Get the battery fully charge:

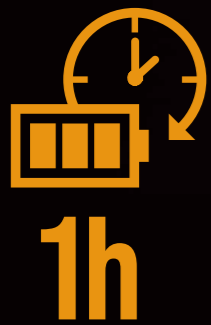

Hangcha High Voltage Electric Forklift



Electric Forklift

HIGH-VOLTAGE

# 422.9Kwh

Battery capacity



# ULTRA LONG BATTERY LIFE

- / A large-capacity lithium battery for the standard configuration can meet the long battery life need.
- / Both the drive and operating systems are efficient and energy-saving vehicle-grade permanent magnet synchronization systems.
- / High-voltage platform, less vehicle current and minimal system heat loss.
- / Braking energy recovery effectively prolongs operating time.



A double-motor walking system increases the range of high efficiency and saves energy significantly.



## Advancement

A high-torque permanent magnet synchronous motor provides strong power for the vehicle with performance indicators benchmarked against that of internal combustion forklifts.

# 618V

A high-voltage platform with low system loss, a standard chilled water tank for heavy-duty truck to achieve good heat dissipation.



With motor, electric control and battery adopting liquid-cooling heat dissipation, the forklift can absolutely carry out long-time and high-intensity operations as internal combustion forklifts.

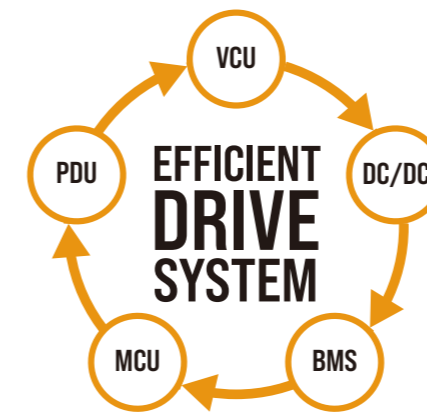

The vehicle has independently developed VCU program along with PDU+MCU+BMS+DC/DC to form a reliable and efficient drive system with flexible function configuration.



## Intelligence

- / A vehicle central controller is provided, which has bus architecture, several built-in diagnosis and management functions and a central fault alarm function.
- / An optional intelligent management system is provided to enable intelligent remote monitoring and easier equipment management and logistics management.



## Maintainability

- / The overturnable cab and electric tipping cylinder make tipping easier and more labor-saving.
- / The wide-opened hood and removable cover better facilitate repair and maintenance of electrical components.



# SAFE AND RELIABLE

- / The cover of the vehicle is designed to be sealed to the water resistance level of IPX4.
- / The electrical system has high-voltage interlocking, insulation monitoring and potential balancing functions to offer vehicle-grade safety.



Key structural parts have been verified highly reliable by the market for many years while being used by internal combustion forklifts.



Both the battery and junction box have MSD maintenance switches to enable one-click power-down and safer maintenance.



All the motor and electronic controls reach the dust and water resistance level of IP67, a high protection level adequate to withstand harsh operating environments.



The high-voltage lithium battery is equipped with an automatic fire extinguisher for the standard configuration. The vehicle is equipped with a pipe network automatic fire extinguisher for the standard configuration.



A turning deceleration function effectively reduces risk of tipping over.

## 38-40t Mast Specification

Type	Model	Max. Fork Height	Lowered	Extended	Front Overhang	Tilt range
						F/R
STD_Duplex	G400M360	3600	4400	6170	1290	6/10
	G400M400	4000	4600	6570	1290	6/10
	G400M430	4300	4750	6870	1260	6/10
	G400M450	4500	4850	7070	1290	6/10
	G400M480	4800	5000	7370	1290	6/10
	G400M500	5000	5100	7570	1290	6/10
	G400M550	5500	5350	8070	1290	3/6
	G400M600	6000	5600	8570	1290	3/6
	G400M650	6500	5850	9070	1290	3/6
	G400M700	7000	6100	9570	1290	3/6

## 46-48t Mast Specification

Type	Model	Max. Fork Height	Lowered	Extended	Front Overhang	Tilt range
						F/R
STD_Duplex	G480M360	3600	4800	6570	1290	6/10
	G480M400	4000	5000	6970	1290	6/10
	G480M430	4300	5150	7270	1260	6/10
	G480M450	4500	5250	7470	1290	6/10
	G480M480	4800	5400	7770	1290	6/10
	G480M500	5000	5500	7970	1290	6/10
	G480M550	5500	5750	8470	1290	3/6
	G480M600	6000	6000	8970	1290	3/6
	G480M650	6500	6250	9470	1290	3/6
	G480M700	7000	6500	9970	1290	3/6

## Features

Truck	Standard	Options
Duplex wide-view mast	●	
Fully hydraulic power steering	●	
Water chilling unit for lithium battery	●	
Traction device	●	
Oil-resistant tread tire	●	
Standard lithium battery box	●	
Standard fork	●	
Fork positioner-equipped side shift fork	●	
Pneumatic tire	●	
Forks of other specifications		○
Solid tire		○
Cab		
Cab	●	
Multi-direction adjustable armrest	●	
Steering wheel adjusting device	●	
Standard seat	●	
Cooling and heating air conditioner	●	
Chair sensing system	●	
Electrically-controlled joystick	●	
Vehicle intercom		○
Controls and instruments		
LCD bus instrument	●	
Multifunctional color-screen instruments	●	
Neutral gear switch	●	
VCU controller	●	
Emergency shut-off switch	●	
MSD maintenance switch	●	
Weighing system		○
Cloud intelligent management system		○
Safety		
Hydraulic oil filter alarm	●	
Snail horn	●	
Visual reversing radar	●	
Accumulator low pressure alarm	●	
Automatic fire extinguisher for lithium battery	●	
Rearview mirror	●	
Reversing buzzer	●	
Reverse voice buzzer		○
Fire extinguisher (2kg/4kg)		○
Speed limit alarm		○
Turning deceleration		○
Maintenance		
Maintenance-free 24V lead-acid battery	●	
Cab electric tipping	●	
Maintenance reminding	●	
Tire pressure monitoring		○
Driving record system		○
Central lubrication system		○
Lights		
Alarm light	●	
Vehicle LED lights	●	
Mast LED light	●	
Blue light		○
Acoustic and optical alarm light		○
Other		
Self-locking valve in the tilting fuel circuit	●	
Neutral indicator	●	
Speed limit valve in the lifting fuel circuit	●	
Vehicle toolkit	●	
Quad multiway valve	●	
User specified color		○

## XH Series High-voltage Lithium Battery Forklift Specification

Distinguishing mark	Item No.	Description	HANGCHA GROUP CO.,LTD.				
			CPD380-XHJG	CPD400-XHJG	CPD460-XHJG	CPD480-XHJG	
	1.1	Manufacturer					
	1.2	Manufacturer's type designation	CPD380-XHJG	CPD400-XHJG	CPD460-XHJG	CPD480-XHJG	
	1.3	Drive: electric (battery or mains), diesel, petrol, fuel gas	Electric	Electric	Electric	Electric	
	1.4	Operator type: hand, pedestrian, standing, seated, order-pickler	Seated	Seated	Seated	Seated	
	1.5	Rated capacity/rated load	kg	38000	40000	46000	48000
	1.6	Load centre distance	c (mm)	1200	1200	1200	1200
	1.8	Load distance, centre of drive axle to fork	x (mm)	1290	1290	1300	1300
	1.9	Wheelbase	y (mm)	5500	5500	5500	5500
Weight	2.1	Service Weight	kg	57000	58000	62000	64500
	2.2	Axle loading, laden front/rear	kg	83500/11500	86900/11100	97600/10400	10170/10800
	2.3	Axle loading, unladen front/rear	kg	28200/28800	28700/23300	30700/31300	31900/32600
Tyres, chassis	3.1	Tyres: solid rubber, superelastic, pneumatic, polyurethane		pneumatic	pneumatic	pneumatic	pneumatic
	3.2	Tyre size, front		18.00-25-40PR	18.00-25-40PR	18.00-25-40PR	18.00-25-40PR
	3.3	Tyre size, rear		18.00-25-40PR	18.00-25-40PR	18.00-25-40PR	18.00-25-40PR
	3.5	Wheels, number front / rear (x = driven wheels)		4x/2	4x/2	4x/2	4x/2
	3.6	Tread, front	b <sub>0</sub> (mm)	3050	3050	3050	3050
	3.7	Tread, rear	b <sub>1</sub> (mm)	2790	2790	2790	2790
	4.1	Tilt of mast/fork carriage forward/backward	α/β (°)	6/10	6/10	6/10	6/10
Dimensions	4.2	Height, mast lowered	h <sub>1</sub> (mm)	4600	4600	5000	5000
	4.3	Free lift	h <sub>2</sub> (mm)	125	125	140	140
	4.4	Lift	h <sub>3</sub> (mm)	4000	4000	4000	4000
	4.5	Height, mast extended	h <sub>4</sub> (mm)	6570	6570	6970	6970
	4.7	Height of overhead guard (cabin)	h <sub>6</sub> (mm)	4120	4120	4120	4120
	4.8	Seat height/stand height	h <sub>7</sub> (mm)	2880	2880	2880	2880
	4.12	Coupling height	h <sub>8</sub> (mm)	880	880	880	880
	4.19	Overall length	l <sub>1</sub> (mm)	10470	10470	10480	10480
	4.2	Length to face of forks	l <sub>2</sub> (mm)	8030	8030	8040	8040
	4.21	Overall width	b <sub>1</sub> /b <sub>2</sub> (mm)	4215	4215	4215	4215
	4.22	Fork dimensions	s / e / l (mm)	125/300/2440	125/300/2440	140/300/2440	140/300/2440
	4.24	Fork-carriage width	b <sub>3</sub> (mm)	3350	3350	3350	3350
	4.31	Ground clearance, laden, below mast	m <sub>1</sub> (mm)	220	220	220	220
	4.32	Ground clearance, centre of wheelbase	m <sub>2</sub> (mm)	390	390	390	390
	4.34.1	Aisle width for pallets 1000 x 1200 crossways	A <sub>st</sub> (mm)	8990+L6	8990+L6	9000+L6	9000+L6
Performance data	4.35	Turning radius	W <sub>a</sub> (mm)	7500	7500	7500	7500
	4.36	Internal turning radius	b <sub>13</sub> (mm)	1000	1000	1000	1000
	5.1	Travel speed, laden/unladen	km/h	24/24	24/24	23/24	23/24
	5.2	Lift speed, laden/unladen	m/s	0.32/0.35	0.32/0.35	0.30/0.32	0.30/0.32
	5.3	Lowering speed, laden/unladen	m/s	0.35/0.35	0.35/0.35	0.35/0.35	0.35/0.35
	5.6	Max. Drawbar pull, laden/unladen	N	230000	230000	230000	230000
	5.8	Max. gradeability, laden/unladen	%	20/25	20/25	20/25	20/25
	5.9	Acceleration time, laden/unladen (0-10m)	s	6.2/5.2	6.2/5.2	6.5/5.5	6.5/5.5
	5.1	Service brake		Wet disc brake system(WDB)	Wet disc brake system(WDB)	Wet disc brake system(WDB)	Wet disc brake system(WDB)
	Parking brake		Spring Applied,Hydraulic release multdisc brake(SAHR)				
Electric engine	6.1	Drive motor rating S2 60 min	kW	214	214	214	214
	6.2	Lift motor rating at S3 15%	kW	89×2	89×2	89×2	89×2
	6.4	Battery voltage, nominal capacity K5	(V)/[Ah]	618/684	618/684	618/684	618/684
	6.5	Battery weight	kg	3500	3500	3500	3500
Addition data	10.1	Operating pressure for attachments	MPa	21	21	21	21
	10.2	Oil volume for attachments	l/min	125	125	125	125

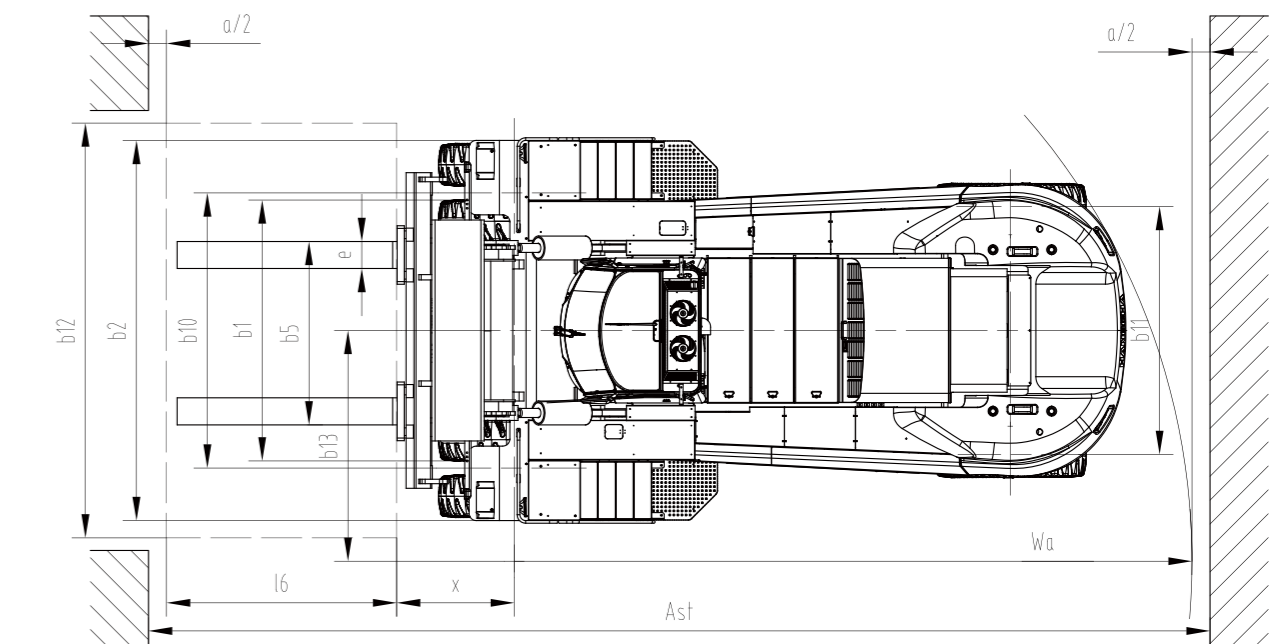
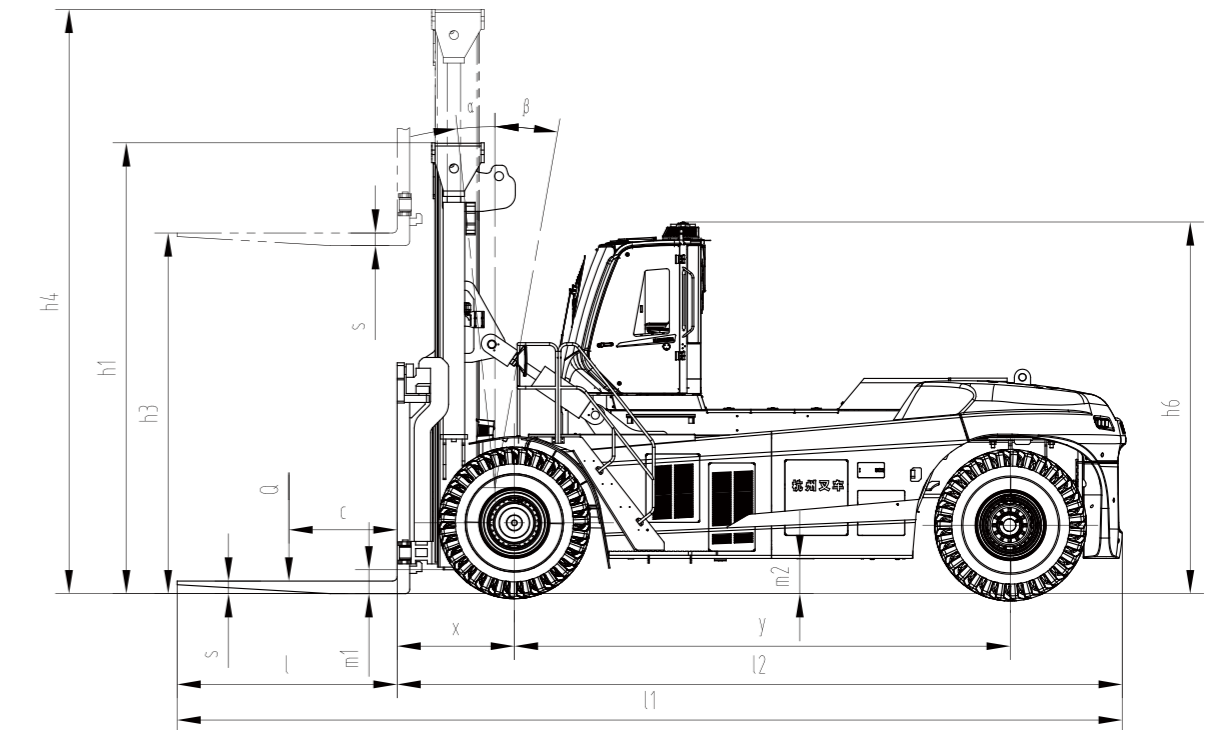

$$A_{st} = l_6 + W_a + x + a \quad L_6: \text{load length} \quad a: \text{Clearance (200mm)}$$

